

# SERIE COBÁ

COBA4, COBA6, COBA8, COBA10, COBA12 y COBA16

MOTOBOMBAS SUMERGIBLES DE CUATRO POLOS (1,750 RPM)  
PARA EFLUENTES (AGUAS RESIDUALES) Y LODOS (AGUAS NEGRAS)

FICHA TÉCNICA

# SERIE COBÁ

COBA4, COBA6, COBA8, COBA10, COBA12 y COBA16

## ESPECIFICACIONES

Altamira serie COBÁ es una gama profesional de motobombas de cuatro polos (1,750 rpm) diseñada para la evacuación de aguas cargadas. Su excelente construcción, amplio rango de desempeño y confiable funcionamiento nos permiten ofrecer una solución eficiente a la mayoría de las necesidades en el mercado.

## APLICACIONES

- Aguas de infiltración y pluviales
- Evacuación de aguas fecales y residuales
- Fosas sépticas
- En general, aguas con carga de sólidos

## CARACTERÍSTICAS DE CONSTRUCCIÓN

Cuerpo:

- Carcasa tipo voluta para una máxima eficiencia, fabricada en hierro fundido

Impulsor:

- Semiabierto, de doble canal, construido en hierro

Sello mecánico:

- Doble sello mecánico en carburo de silicio
- Eje en acero inoxidable 420

Cable:

- Incluye 10 m de cable sumergible tomacorriente
- Cuenta con sensores por alta temperatura y detección de fuga en el sello.
- Tornillería de la motobomba en acero inoxidable 304

## MOTOR

- Asíncrono, servicio continuo (cuando la bomba está totalmente sumergida).
- Cuatro polos (1,750 RPM)
- Aislamiento clase F
- Protección IP68
- Motor de 6 hilos en las siguientes potencias y voltajes: 25 HP en 230V , 50HP, 60HP, 75HP y 100HP en 460V.

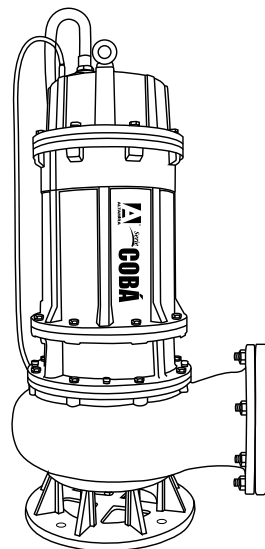

## CARACTERÍSTICAS DE OPERACIÓN

- Máxima temperatura del líquido: 35°C
- Rango de pH del líquido a bombear: 6.5 a 8.5
- Densidad del líquido: 1.3g/cm<sup>3</sup>
- Profundidad máxima de inmersión: 10 m

## DESCRIPCIÓN DEL CÓDIGO

<b>COBA / 8 / 200 3460</b>			
<b>Serie</b> COBÁ			
<b>Descarga en pulgadas</b> 4 = 4" 6 = 6" 8 = 8" 10 = 10" 12 = 12" 16 = 16"		<b>Potencia nominal del motor en HP X 10</b> 200 = 20HP X 10	<b>Voltaje del motor</b> 230 = 230V 460 = 460V
			<b>Número de fases</b> 3 = 3 fases

## CURVAS DE OPERACIÓN

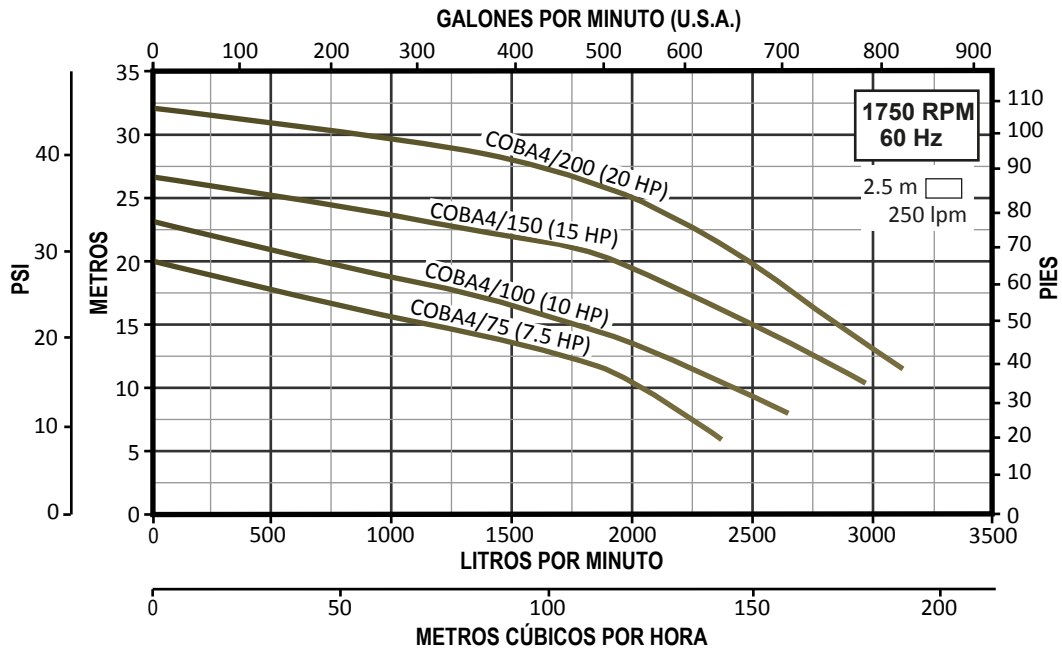

## TABLA DE ESPECIFICACIONES

CÓDIGO	HP	KW	FASES X VOLTS	A	PASO DE SÓLIDOS EN SUSPENSIÓN (pulgadas)	CARGA EN METROS (psi)				
						10	15	20	25	30
						(14.2)	(21.3)	(28.4)	(35.5)	(42.6)
						GASTO (litros por minuto)				
COBA4/75/3230	7.5	5.5	3 x 230	19.3	2"	2080	1180			
COBA4/75/3460			3 x 460	10						
COBA4/100/3230	10	7.5	3 x 230	26		2440	1750	720		
COBA4/100/3460			3 x 460	13						
COBA4/150/3230	15	11	3 x 230	38		3000	2500	1900	570	
COBA4/150/3460			3 x 460	19						
COBA4/200/3230	20	15	3 x 230	52			2880	2500	2000	900
COBA4/200/3460			3 x 460	26						

## CURVAS DE OPERACIÓN

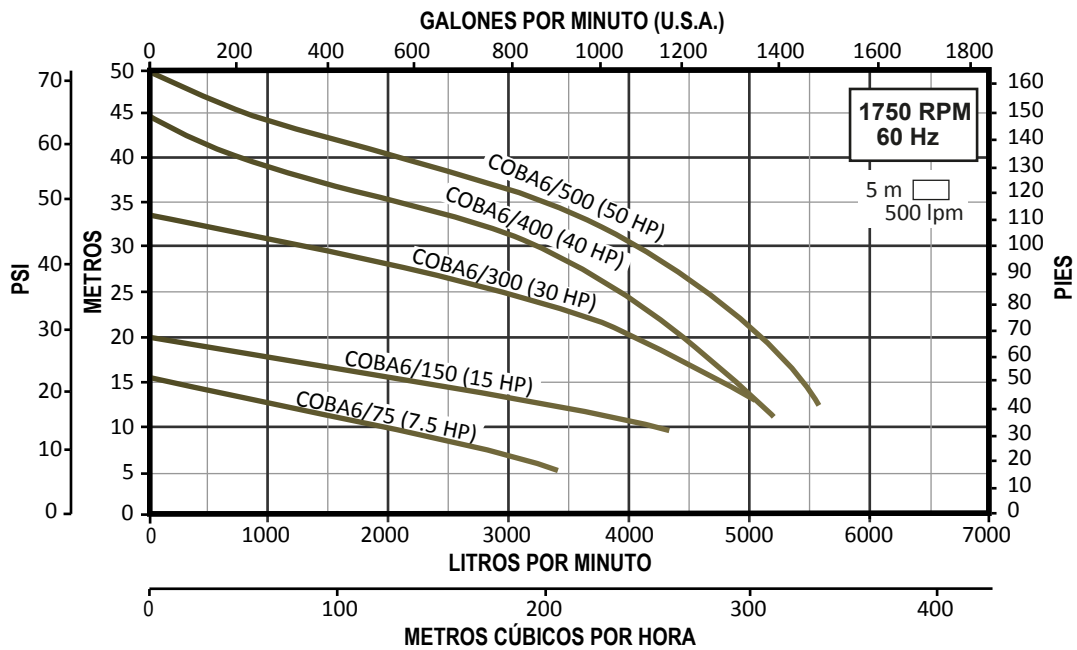

## TABLA DE ESPECIFICACIONES

CÓDIGO	HP	KW	FASES X VOLTS	A	PASO DE SÓLIDOS EN SUSPENSIÓN (pulgadas)	CARGA EN METROS (psi)							
						5	10	15	20	25	30	35	40
						(7.1)	(14.2)	(21.3)	(28.4)	(35.5)	(42.6)	(49.7)	(56.8)
GASTO (litros por minuto)													
COBA6/75/3230	7.5	5.5	3 x 230	19.3	2"	3400	1900	200					
COBA6/75/3460			3 x 460	10									
COBA6/150/3230	15	11	3 x 230	38	2.4"		4200	2100					
COBA6/150/3460			3 x 460	19									
COBA6/300/3460	30	22		37			4750	4000	2900	1300			
COBA6/400/3460	40	30	3 x 460	47.5	2.7"				5100	4100	2700	1000	
COBA6/500/3460	50	37		57.5					6250	5500	4500	3000	1200

# CURVAS DE OPERACIÓN

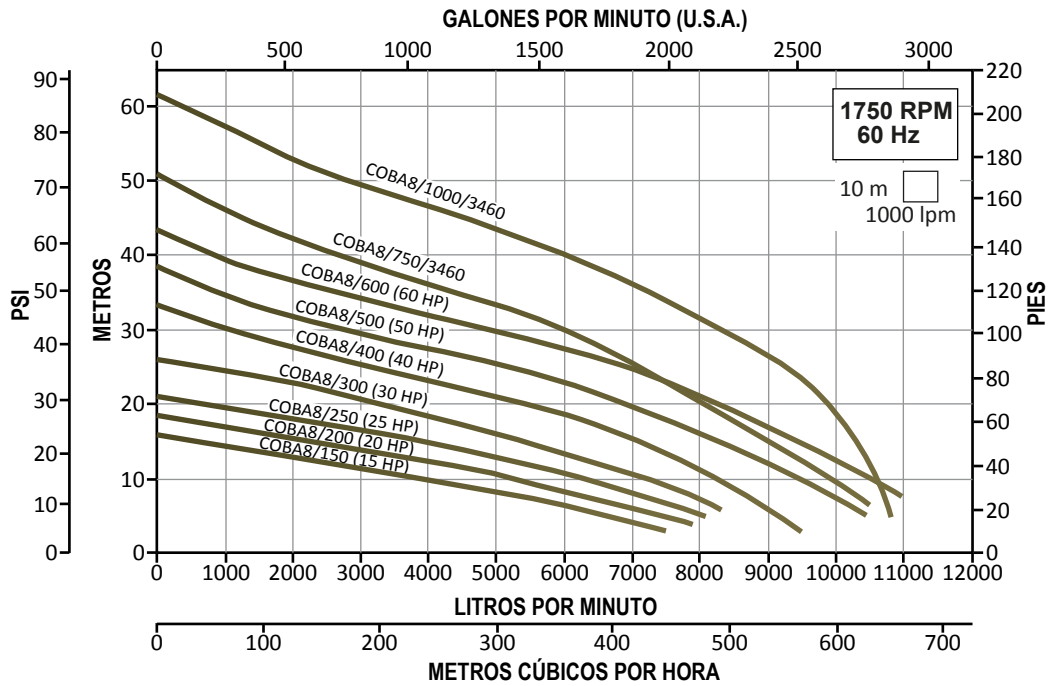

## TABLA DE ESPECIFICACIONES

CÓDIGO	HP	KW	FASES X VOLTS	A	PASO DE SÓLIDOS EN SUSPENSIÓN (pulgadas)	CARGA EN METROS (psi)																
						5	10	15	20	25	30	35	40	45	50	55	60					
						(7.1)	(14.2)	(21.3)	(28.4)	(35.5)	(42.6)	(49.7)	(56.8)	(63.9)	(71)	(78.1)	(85.2)					
GASTO (litros por minuto)																						
COBA8/150/3230	15	11	3 x 230	38	2.5"	6700	4150	1000														
COBA8/150/3460	15	11	3 x 460	19		7700	5400	2500														
COBA8/200/3230	20	15	3 x 230	50		8120	6550	4300	1250													
COBA8/200/3460	20	15	3 x 460	25																		
COBA8/250/3230	25	18.5	3 x 230	63																		
COBA8/250/3460	25	18.5	3 x 460	31.5	2.7"																	
COBA8/300/3460	30	22		37				7480	5600	3700	900											
COBA8/400/3460	40	30		47.5				8000	6600	4900	2750											
COBA8/500/3460	50	37		57.5				9400	8250	7100	5050	3150	900									
COBA8/600/3460	60	45		70						10850	9600	7450	5000	2450								
COBA8/750/3460	75	55	3.14"	86.7				11100	10250	9400	8250	7000	5450	3550	1600	450						
COBA8/1000/3460	100	75		116.5					11700	11300	10400	9500	8400	7250	5650	3500	2000	550				

## CURVAS DE OPERACIÓN

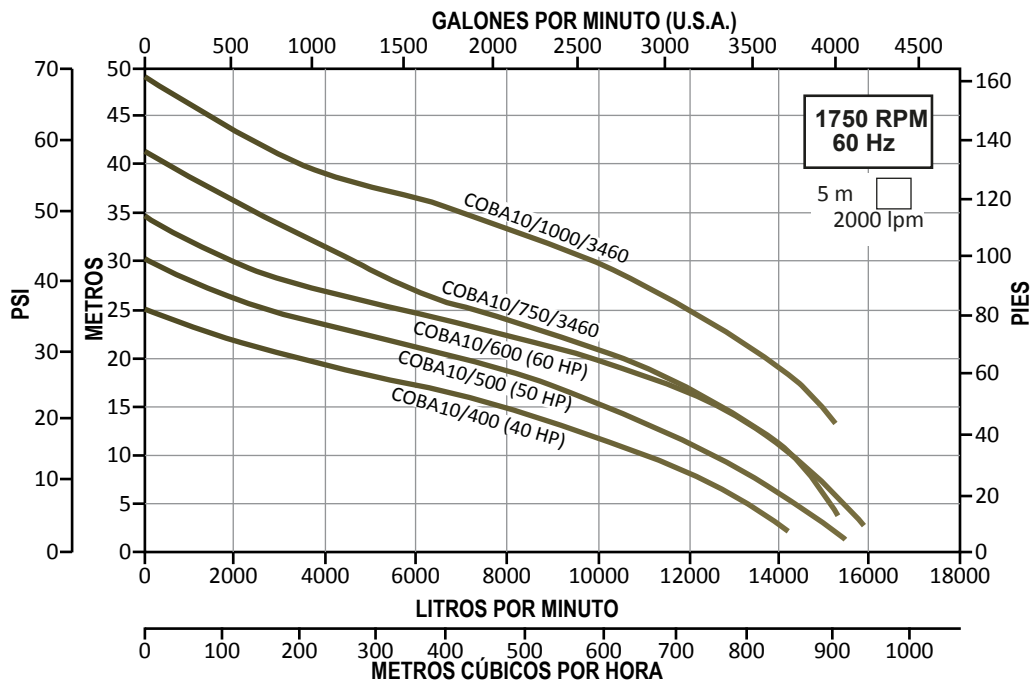

## TABLA DE ESPECIFICACIONES

CÓDIGO	HP	KW	FASES X VOLTS	A	PASO DE SÓLIDOS EN SUSPENSIÓN (pulgadas)	CARGA EN METROS (psi)								
						5	10	15	20	25	30	35	40	45
						(7.1)	(14.2)	(21.3)	(28.4)	(35.5)	(42.6)	(49.7)	(56.8)	(63.9)
												GASTO (litros por minuto)		
COBA10/400/3460	40	30	3 x 460	47.5	2.7"	12800	9900	5600						
COBA10/500/3460	50	37		57.5		14500	12150	9100	4150					
COBA10/600/3460	60	45		70			13900	11350	7200	2600				
COBA10/750/3460	75	55		86.7	3.5"	15150	14300	12700	10500	7300	4600	2450	500	
COBA10/1000/3460	100	75		116.5				14950	13650	12000	9900	6950	3600	1500

## CURVAS DE OPERACIÓN

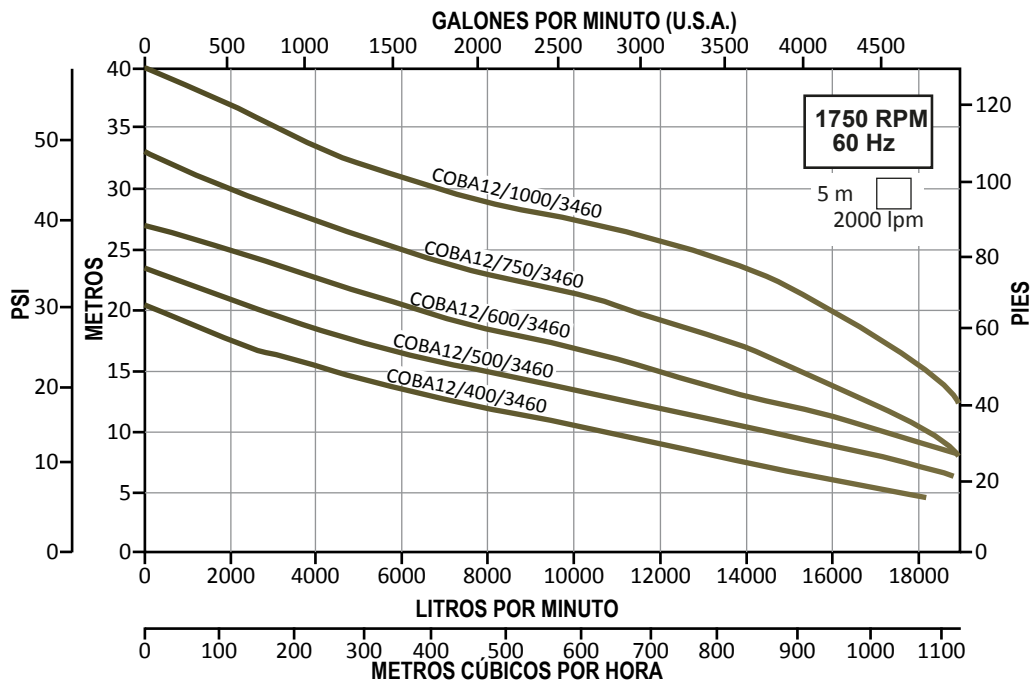

## TABLA DE ESPECIFICACIONES

CÓDIGO	HP	KW	FASES X VOLTS	A	PASO DE SÓLIDOS EN SUSPENSIÓN (pulgadas)	CARGA EN METROS (psi)						
						5	10	15	20	25	30	35
						(7.1)	(14.2)	(21.3)	(28.4)	(35.5)	(42.6)	(49.7)
GASTO (litros por minuto)												
COBA12/400/3460	40	30	3 x 460	49	3.5"	17600	10650	4500	400			
COBA12/500/3460	50	37		59			14600	8000	2800			
COBA12/600/3460	60	45		71.5			17300	12000	6400	2000		
COBA12/750/3460	75	55		86.7			20000	18400	15300	11400	6000	2000
COBA12/1000/3460	100	75		116.5			20350	19500	18400	16000	12800	7000

## CURVAS DE OPERACIÓN

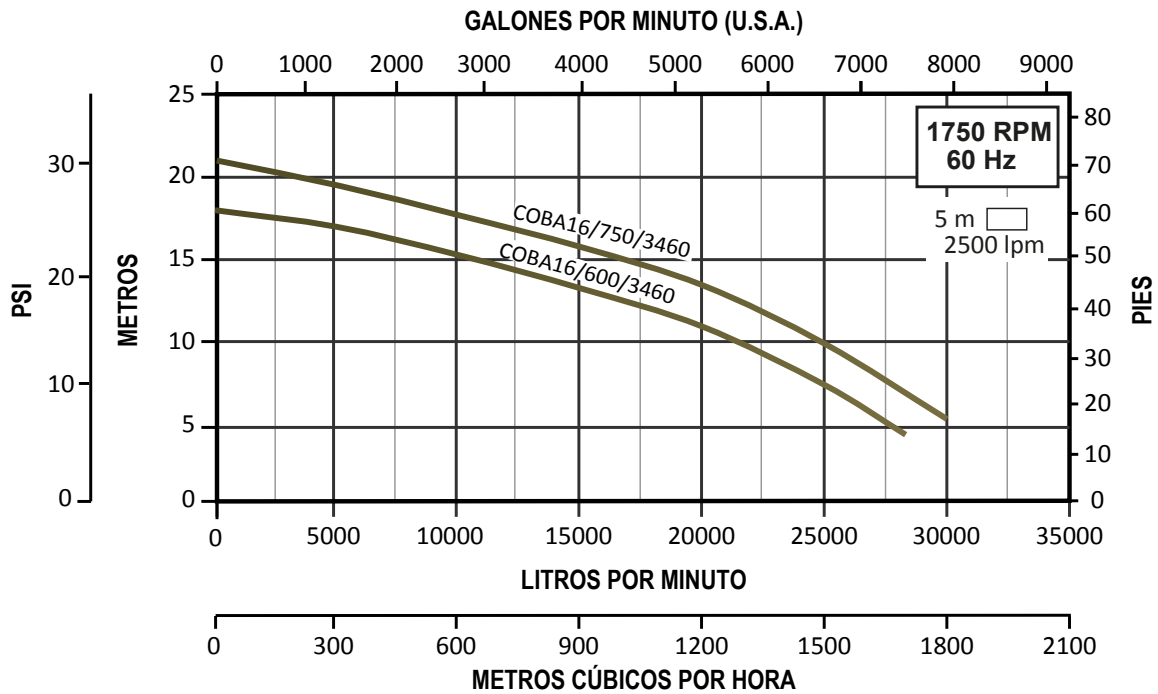

## TABLA DE ESPECIFICACIONES

CÓDIGO	HP	KW	FASES X VOLTS	A	PASO DE SÓLIDOS EN SUSPENSIÓN (pulgadas)	CARGA EN METROS (psi)						
						6	9	12	15	18	21	
						(8.5)	(12.8)	(17.0)	(21.3)	(25.6)	(29.8)	
							GASTO (litros por minuto)					
NUEVOS	COBA16/600/3460	60	45	3 x 460	85	4.7"	27000	22500	18500	10000	0	
	COBA16/750/3460	75	55		105		29000	26500	23000	17000	10000	0



## DIMENSIONES Y PESOS

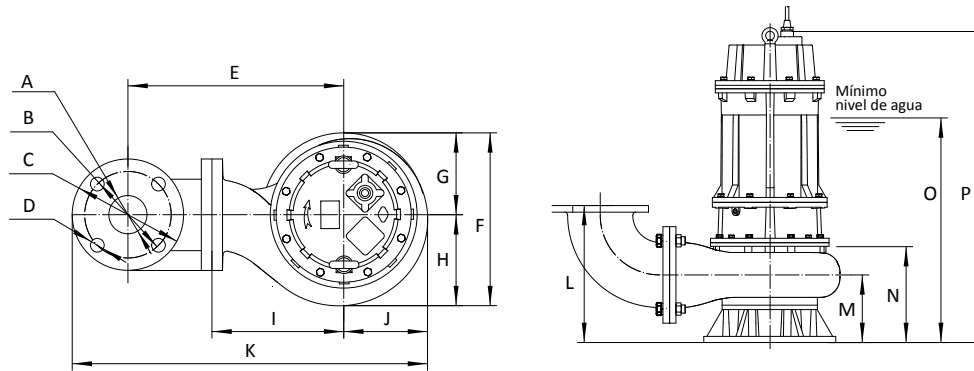

CÓDIGO	DIMENSIONES																PESOS (kg)	
	PULGADAS				mm												NETO	BRUTO
	A	B	C	D	E	F	G	H	I	J	K	L	M	N	O	P		
COBA4/75	100	170	210	4 - Ø18	432	382	180	202	280	190	727	340	190	255	585	805	149	170
COBA4/100															630	850	165	180
COBA4/150															650	910	259	280
COBA4/200															695	955	281	300

Nota: El codo de descarga se vende por separado

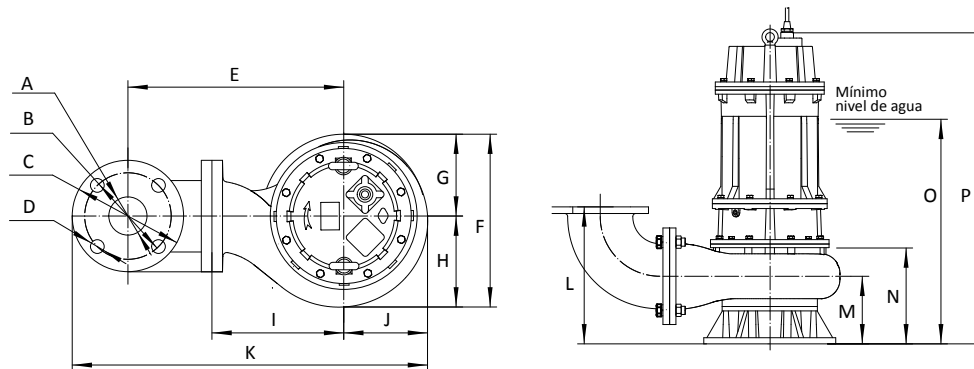

CÓDIGO	DIMENSIONES																PESOS (kg)					
	PULGADAS				mm												NETO	BRUTO				
	A	B	C	D	E	F	G	H	I	J	K	L	M	N	O	P						
COBA6/75	150	225	265	8 - Ø18	502	400	185	215	300	200	834	405	205	285	615	835	162	180				
COBA6/150					522	435	210	225	320	210	865	415	215		680	940	264	290				
COBA6/300/3460					537	445		235	335	220	890				760	1055	355	380				
COBA6/400/3460					240	280	8 - Ø22	582	553	270	283	380	272		997	450	250	340	855	1200	505	530
COBA6/500/3460								850	1255	565	590											

Nota: El codo de descarga se vende por separado

## DIMENSIONES Y PESOS

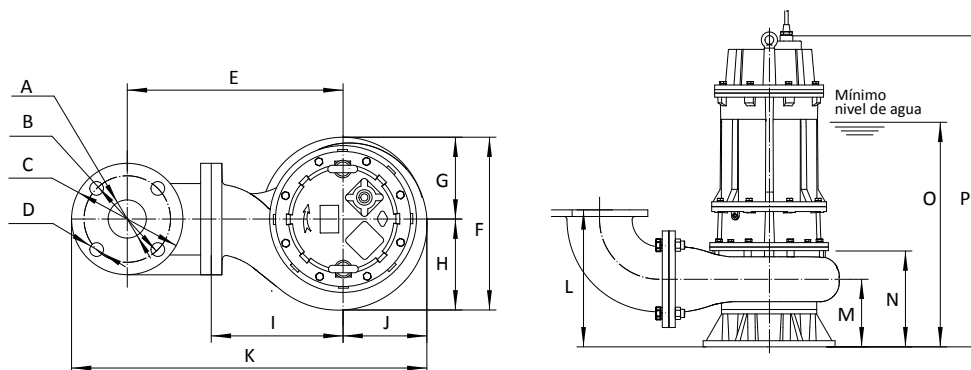

CÓDIGO	DIMENSIONES																PESOS (kg)	
	PULGADAS				mm												NETO	BRUTO
	A	B	C	D	E	F	G	H	I	J	K	L	M	N	O	P		
COBA8/150					572	463		253	340	225	968				720	980	288	310
COBA8/200							210					465	235	325	765	1025	310	330
COBA8/250								260	350	233	985				785	1080	362	390
COBA8/300/3460					582	470									805	1100	382	410
COBA8/400/3460	200	295	340	8 - Ø22											895	1240	527	550
COBA8/500/3460					622	578	270	308	390	286	1078	500	270	380	890	1295	584	610
COBA8/600/3460															930		620	650
COBA8/750/3460															1050	1540	817	850
COBA8/1000/3460					673	643	320	323	440	320	1163	524	294	400	1110		892	930

Nota: El codo de descarga se vende por separado

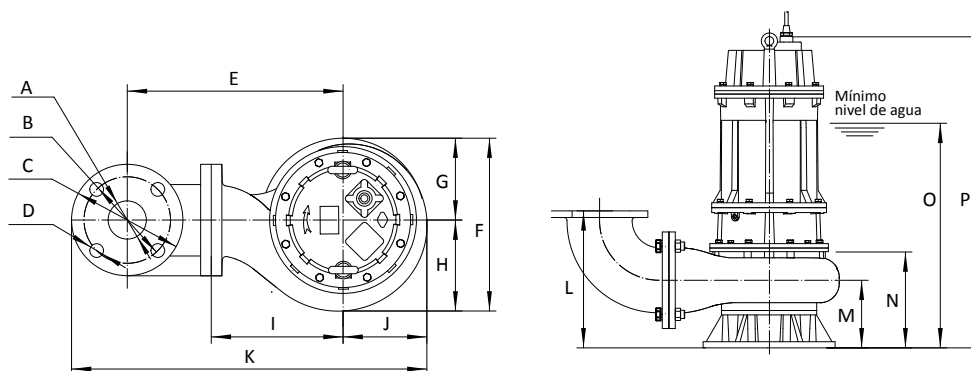

CÓDIGO	DIMENSIONES																PESOS (kg)	
	PULGADAS				mm												NETO	BRUTO
	A	B	C	D	E	F	G	H	I	J	K	L	M	N	O	P		
COBA10/400/3460															920	1265	559	590
COBA10/500/3460					683	602	270	332	410	300	1181	545	275	400	910	1315	617	640
COBA10/600/3460	250	350	395	12 - Ø22											950		653	680
COBA10/750/3460															1080	1575	849	890
COBA10/1000/3460					733	669	320	349	460	320	1250	582	312	440	1140		919	960

Nota: El codo de descarga se vende por separado

## DIMENSIONES Y PESOS

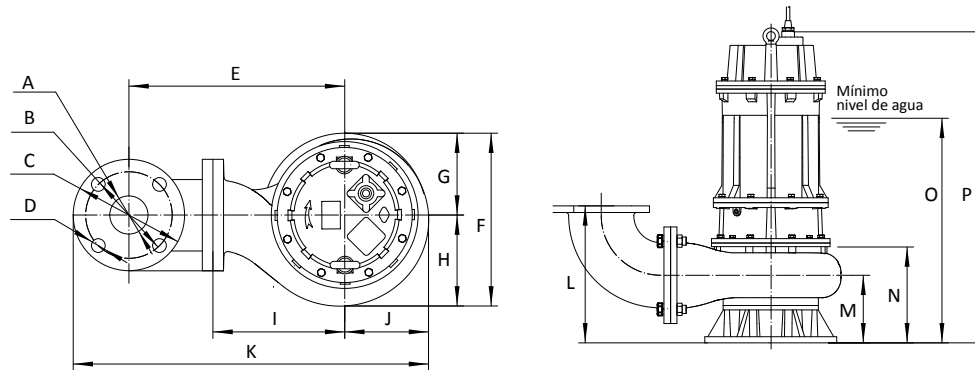

CÓDIGO	DIMENSIONES																PESOS (kg)	
	PULGADAS				mm												NETO	BRUTO
	A	B	C	D	E	F	G	H	I	J	K	L	M	N	O	P		
COBA12/400/3460															970	1315	602	630
COBA12/500/3460					803	676	290	386	480	340	1365	630	310	450	960	1365	659	690
COBA12/600/3460	300	400	445	12 - Ø22											1000		695	720
COBA12/750/3460					813	718	320	398	490	359	1394	649	329	470	1110	1610	879	920
COBA12/1000/3460															1170		953	990

Nota: El codo de descarga se vende por separado

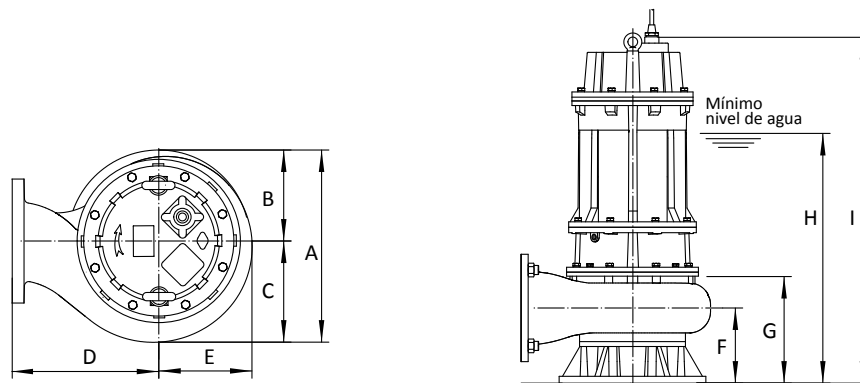

	CÓDIGO	DIMENSIONES EN mm									PESOS (kg)	
		A	B	C	D	E	F	G	H	I	NETO	BRUTO
NUEVO	COBA16/600/3460	857	367	490	600	430	364	540	1190	1674	975	1020
NUEVO	COBA16/750/3460								1230		1028	1080



# COBÁ



**1 AÑO DE FORMA DIRECTA**

**+**

**1 AÑO AL UTILIZAR EL TABLERO  
ALTAMIRA PARA CÁRCAMO / DST**  
(Detección de fuga en el sello y alta temperatura)

**CONSTRUCCIÓN · DESEMPEÑO · CONFIABILIDAD**

