

SERIE STRONG

STRONG2H, STRONG2F, STRONG3 y STRONG4

BOMBA SUMERGIBLE PARA EFLUENTES (AGUAS RESIDUALES)
Y LODOS (AGUAS NEGRAS)

FICHA TÉCNICA

SERIE STRONG

ESPECIFICACIONES

ALTAMIRA STRONG es una gama de bombas profesionales, diseñadas y construidas para cumplir con los requerimientos más exigentes del mercado.

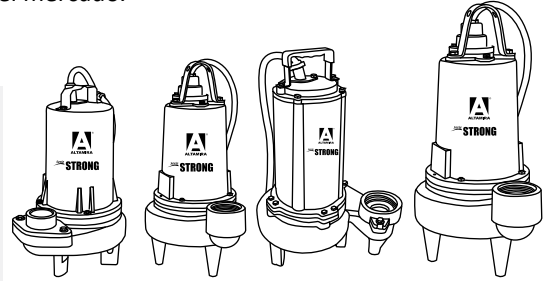
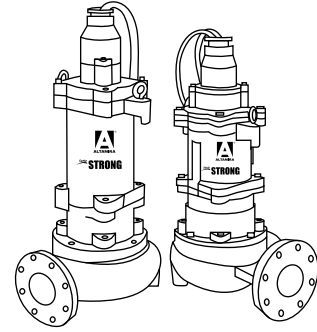

APLICACIONES

- Aguas de infiltración y pluviales
- Evacuación de aguas fecales y residuales
- Fosas sépticas
- En general, aguas con carga de sólidos

CARACTERÍSTICAS DE CONSTRUCCIÓN

- **Cuerpo:**
STRONG2H, STRONG2F, STRONG3 y STRONG4 carcasa tipo voluta para una máxima eficiencia, fabricada en hierro fundido
- **Impulsor:**
STRONG2H: tipo Vortex, construido en hierro
STRONG2F, STRONG3: semiabierto, construido en hierro
STRONG4: diseño cerrado para una alta eficiencia, construido en hierro
- **Sello mecánico:**
STRONG2H,STRONG2F, y STRONG3: cerámica/carbón
STRONG4: doble sello de carburo de silicio, carbón/vitón
- **Eje en acero inoxidable 430**
- **Cable:**
STRONG2H,STRONG2F y STRONG3: incluye 6 m de cable sumergible tomacorriente
STRONG4: Incluye 10 metros de cable sumergible tomacorriente
STRONG4: cuenta con dos sensores para protección contra humedad y temperatura (protegiendo así el motor y sello mecánico)
- **Tornillería en acero inoxidable**

Motor

- Asíncrono refrigerado por inmersión en aceite, servicio continuo (cuando la bomba está totalmente sumergida).
- STRONG2H: dos polos (3450 RPM)
- STRONG2F, STRONG3 y STRONG4: cuatro polos (1750 RPM)
- STRONG2H Y 2F: aislamiento clase F
- STRONG3 Y STRONG4: aislamiento clase H
- STRONG2H y STRONG2F: con protector térmico incluido
- Protección: IP68

DESCRIPCIÓN DEL CÓDIGO

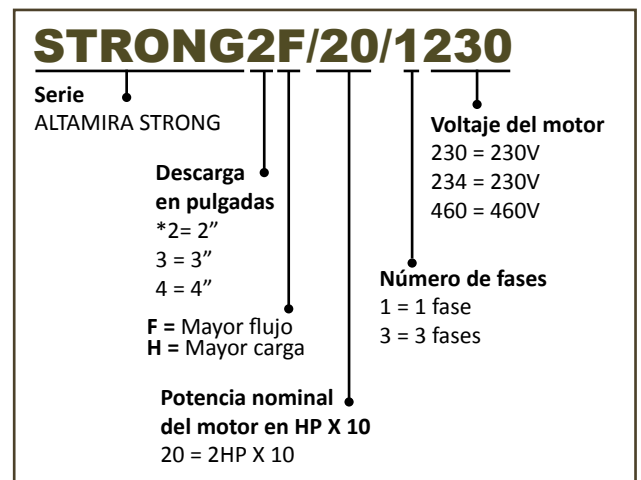

*Nota: Los modelos STRONG2F cuentan con descarga en 3"

CURVAS DE OPERACIÓN



TABLA DE ESPECIFICACIONES

CÓDIGO	HP	KW	FASES X VOLTS	AMP.	PASO DE SÓLIDOS EN SUSPENSIÓN (pulgadas)	CARGA EN METROS (psi)														
						2	4	6	8	10	12	14	16	18	20	22				
						(2.8)	(5.6)	(8.5)	(11.3)	(14.2)	(17)	(19.8)	(22.7)	(25.5)	(28.4)	(31.2)				
						GASTO (litros por minuto)														
STRONG2H/10/1230	1	0.75	1 X 230	11	2"			520	460	390	300	190	70							
STRONG2F/10/1230				10.8		790	650	490	310	110										
STRONG2H/20/1230	2	1.5	1 X 230	18						600	525	450	360	260	150	40				
STRONG2F/20/1230				16.7		975	855	738	639	480	308	88								

DIMENSIONES Y PESOS

CÓDIGO	DIMENSIONES						PESOS (kg)
	mm					pulgadas	
	A	B	C	D	E	F	
STRONG2H/10/1230	360.6	261.6	140	508	203.2	2" NPT	35
STRONG2F/10/1230	403	294.6		563.8	563.8	3" NPT	
STRONG2H/20/1230	360.6	261.6	140	508	203.2	2" NPT	38
STRONG2F/20/1230	403	294.6		563.8	563.8	3" NPT	

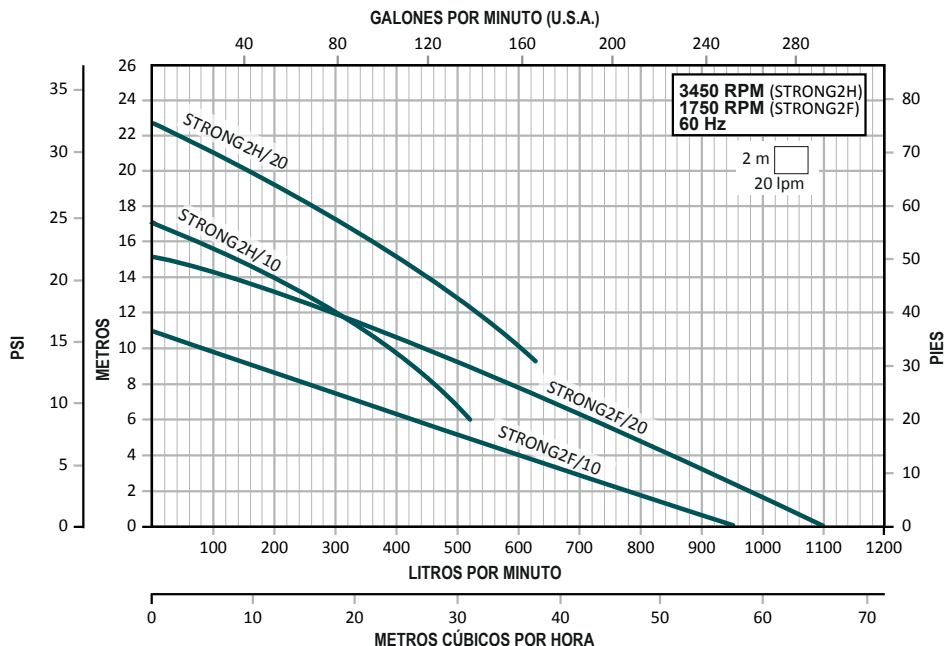
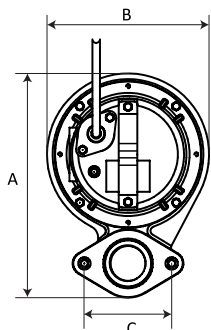

STRONG2H/10, STRONG2H/20

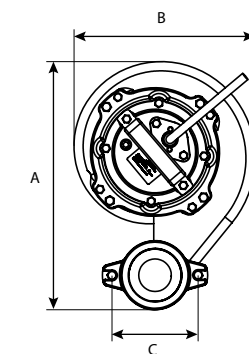
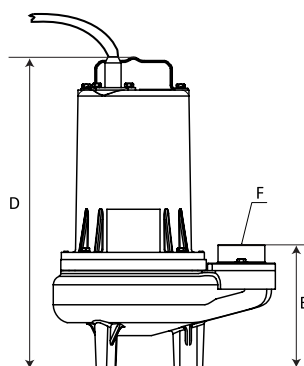

STRONG2F/10, STRONG2F/20

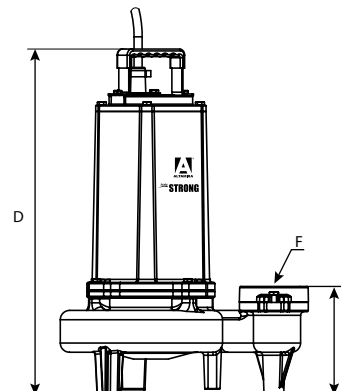

CURVAS DE OPERACIÓN



TABLA DE ESPECIFICACIONES

CÓDIGO	HP	KW	FASES X VOLTS	AMP.	PASA DE SÓLIDOS EN SUSPENSIÓN (pulgadas)	CARGA EN METROS (psi)						
						3 (4.2)	6 (8.5)	9 (12.7)	12 (17)	15 (21.3)	18 (25.5)	
						GASTO (litros por minuto)						
STRONG3/20/3234	2	1.5	3 x 230	20	2.5"	1280	1080	810	500			
STRONG3/20/3460			3 x 460	10								
STRONG3/40/3234	4	2.9	3 x 230	23.6		1920	1700	1415	1120	700		
STRONG3/40/3460			3 x 460	11.8								

DIMENSIONES Y PESO

CÓDIGO	DIMENSIONES						PESOS (kg)
	(mm)					(pulgadas)	
	A	B	C	D	E	F	
STRONG3/20/3234	425.4	56.8	317.5	666.7	250.8	3" NPT	75
STRONG3/20/3460							
STRONG3/40/3234							
STRONG3/40/3460							

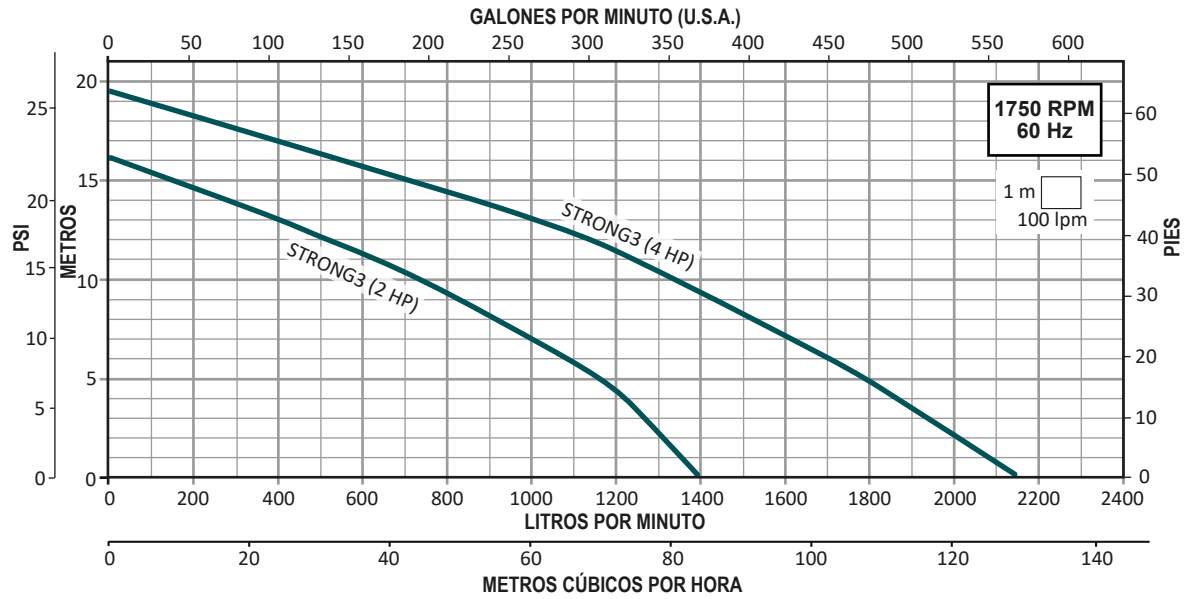
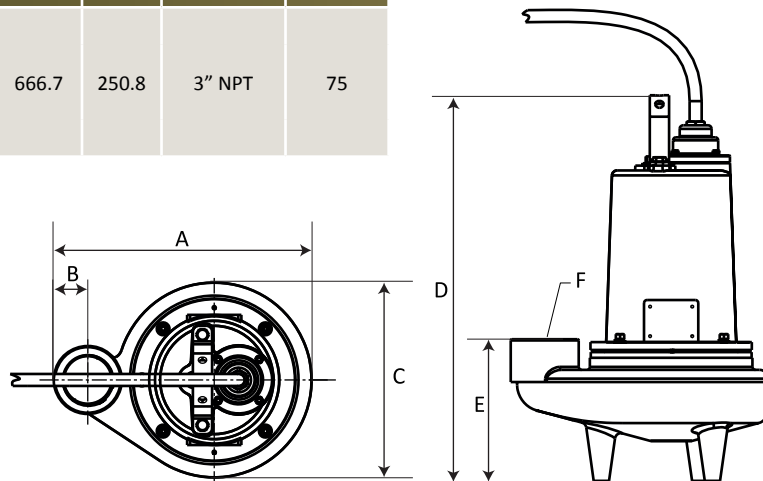

CURVAS DE OPERACIÓN



TABLA DE ESPECIFICACIONES

CÓDIGO	HP	KW	FASES X VOLTS	AMP.	PASO DE SÓLIDOS EN SUSPENSIÓN (pulgadas)	CARGA EN METROS (psi)					
						3 (4.2)	6 (8.5)	9 (12.7)	12 (17)	15 (21.3)	18 (25.5)
						GASTO (litros por minuto)					
STRONG4/50/3234	5	3.7	3 x 230	28	3"	2400	1350	550			
STRONG4/50/3460			3 x 460	14							
STRONG4/75/3234	7.5	5.5	3 x 230	33		2300	1150	400			
STRONG4/75/3460			3 x 460	16.5							
STRONG4/100/3234	10	7.46	3 x 230	45		3100	2100	1000	300		
STRONG4/100/3460			3 x 460	22.5							
STRONG4/150/3234	15	11	3 x 230	55		2850	1800	800	300		
STRONG4/150/3460			3 x 460	27.5							

DIMENSIONES Y PESOS

CÓDIGO	DIMENSIONES									PESOS (kg)
	(mm)								(pulgadas)	
	A	B	C	D	E	F	G	H	I	
STRONG4/50/3234	425.4	266.7	158.7	317.5	139.7	177.8	228.6	742.9	4"	126
STRONG4/50/3460								742.9		
STRONG4/75/3234	444.5	263.5	181	365	160.3	204.7	228.6	854	4"	141
STRONG4/75/3460										141
STRONG4/100/3234										152
STRONG4/100/3460	152									
STRONG4/150/3234	444.5	263.5	181	365	160.3	204.7	228.6	854	4"	152
STRONG4/150/3460										160

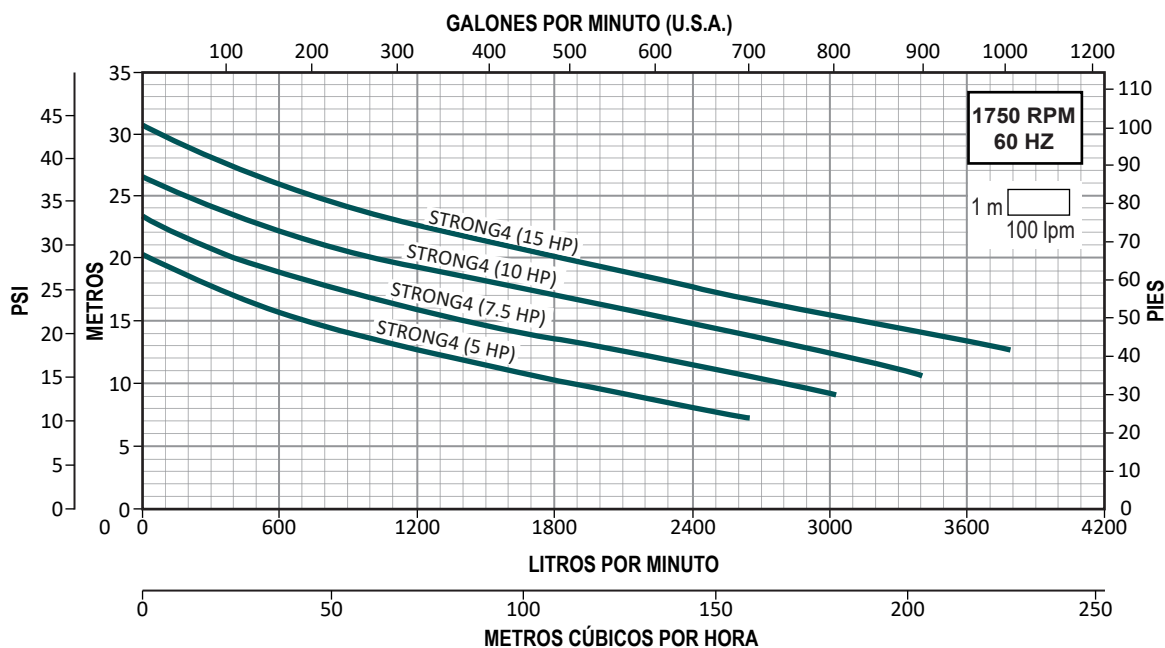
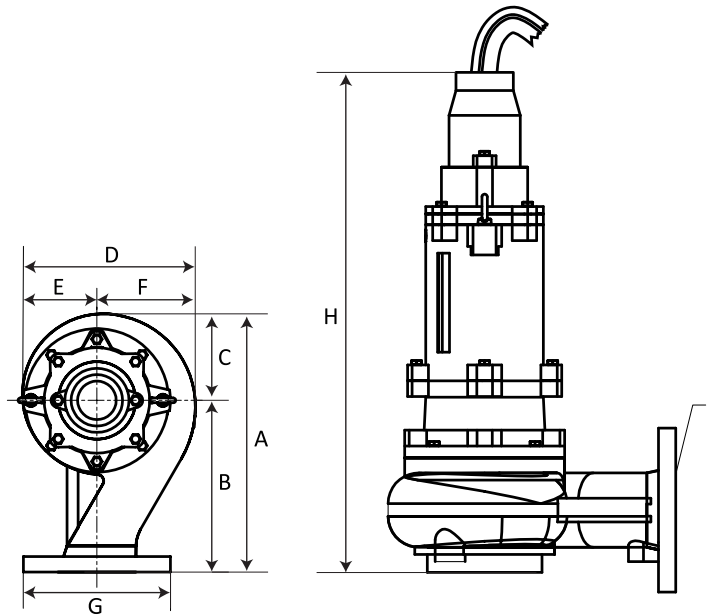

STRONG4/50

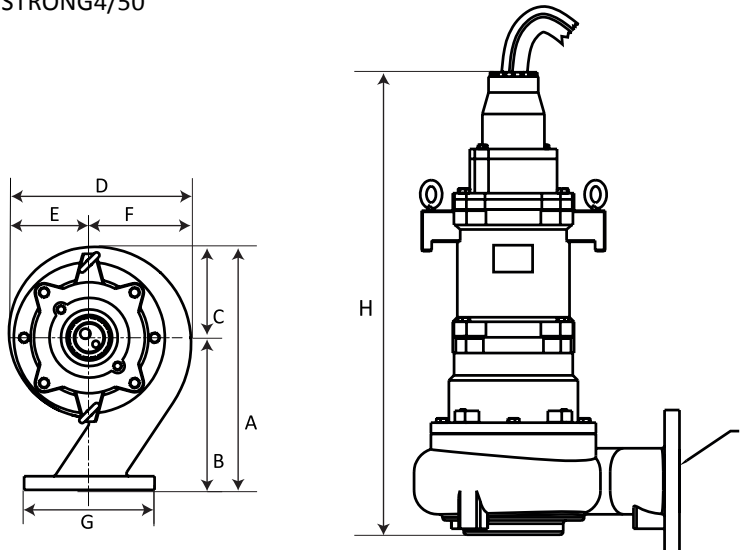

STRONG4/75/, STRONG4/100/ y STRONG4/150/



ALTAMIRA



STRONG

BOMBA SUMERGIBLE PARA EFLUENTES Y LODOS

