



**Barmesa®  
Pumps**

The Professional's Choice™

**WELLXTROL®**  
Well Above The Rest®

Tanques precargados  
para aplicaciones comerciales  
e industriales.

1 año de garantía.



**Presión de trabajo de 175 y 250 PSI.**

- Cilindro de acero de alta resistencia  
aprobado por ASME.

**Diafragma de butilo.**

- Material de alta resistencia y  
flexibilidad para una larga vida de uso.

**Revestimiento antimicrobial.**

- Cuenta con los requerimientos  
internacionales estándar de NSF®  
61 y ANSI.

**Sistema de conexión.**

- Hierro moldeable (NPTF).

**Sistema *Turbulator*™**

- El difusor patentado agita la  
corriente entrante de agua para  
reducir sedimentos.



**Calidad, fiabilidad y rendimiento.**

## ASME - 175 PSI

MODELO	CAPACIDAD		FACTOR DE ACEPT. MÁX.	DIMENSIONES					DESCARGA	PESO (kg) APROX.
	(galones)	(litros)		A	B	C	D	E		
WX401C-175	18	68	0.65	31"	16"	5"	1½"	12¾"	1"	50
WX402C-175	25	95	0.45	40"	16"	5"	1½"	12¾"	1"	57
WX403C-175	34	129	0.33	49"	16"	5"	1½"	12¾"	1"	66
WX404C-175	68	258	0.50	48"	24"	6"	1⅝"	16"	1¼"	142
WX405C-175	90	341	0.39	59"	24"	6"	1⅝"	16"	1¼"	174
WX406C-175	110	417	0.31	70"	24"	6"	1⅝"	16"	1¼"	182
WX407C-175	132	500	0.35	57"	30"	10"	1¾"	24"	1¼"	231

## ASME - 250 PSI

MODELO	CAPACIDAD		FACTOR DE ACEPT. MÁX.	DIMENSIONES					DESCARGA	PESO (kg) APROX.
	(galones)	(litros)		A	B	C	D	E		
WX401C-250	18	68	0.65	31"	16"	5"	1½"	12¾"	1"	57
WX402C-250	25	95	0.45	40"	16"	5"	1½"	12¾"	1"	65
WX403C-250	34	129	0.33	49"	16"	5"	1½"	12¾"	1"	83
WX404C-250	68	258	0.50	48"	24"	6"	1⅝"	16"	1¼"	186
WX405C-250	90	341	0.39	59"	24"	6"	1⅝"	16"	1¼"	196
WX406C-250	110	417	0.31	70"	24"	6"	1⅝"	16"	1¼"	215
WX407C-250	132	500	0.35	57"	30"	10"	1¾"	24"	1¼"	259

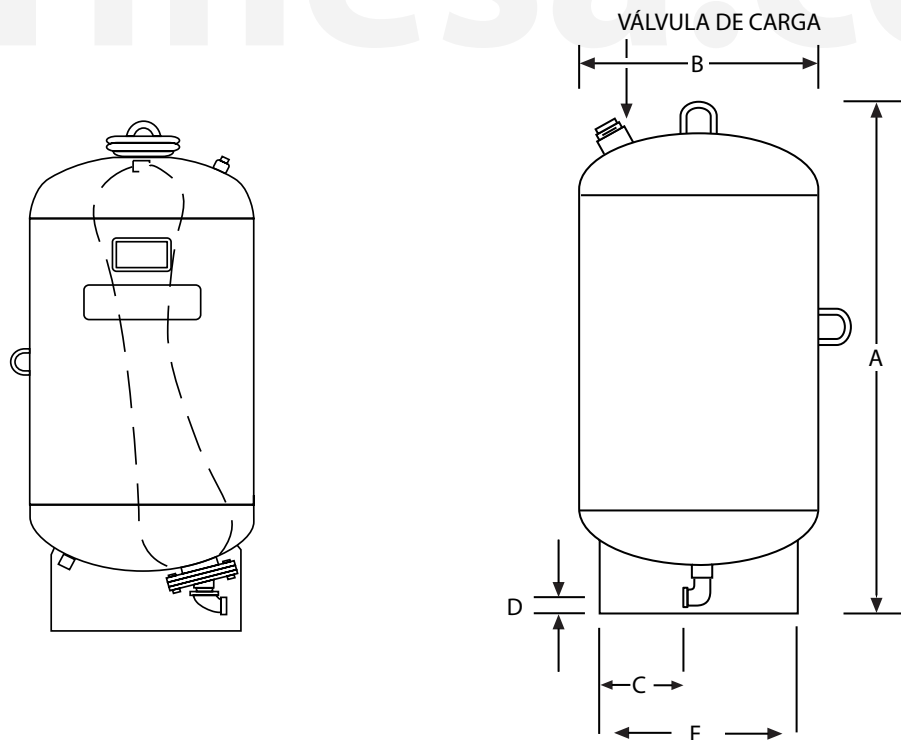

### Barnes de México, S.A. de C.V.

D. Ladrón de Guevara 302 ote. C.P. 64500 Monterrey N.L. México  
(81) 8863-3737 • (81) 8351-3737 • fax (81) 8331-1777

ventas@barnes.com.mx

[www.barnes.com](http://www.barnes.com)